

SecurSCAN®
SICUREZZA
www.securscan.eu

Tornello a Tripode
T2L-Pass

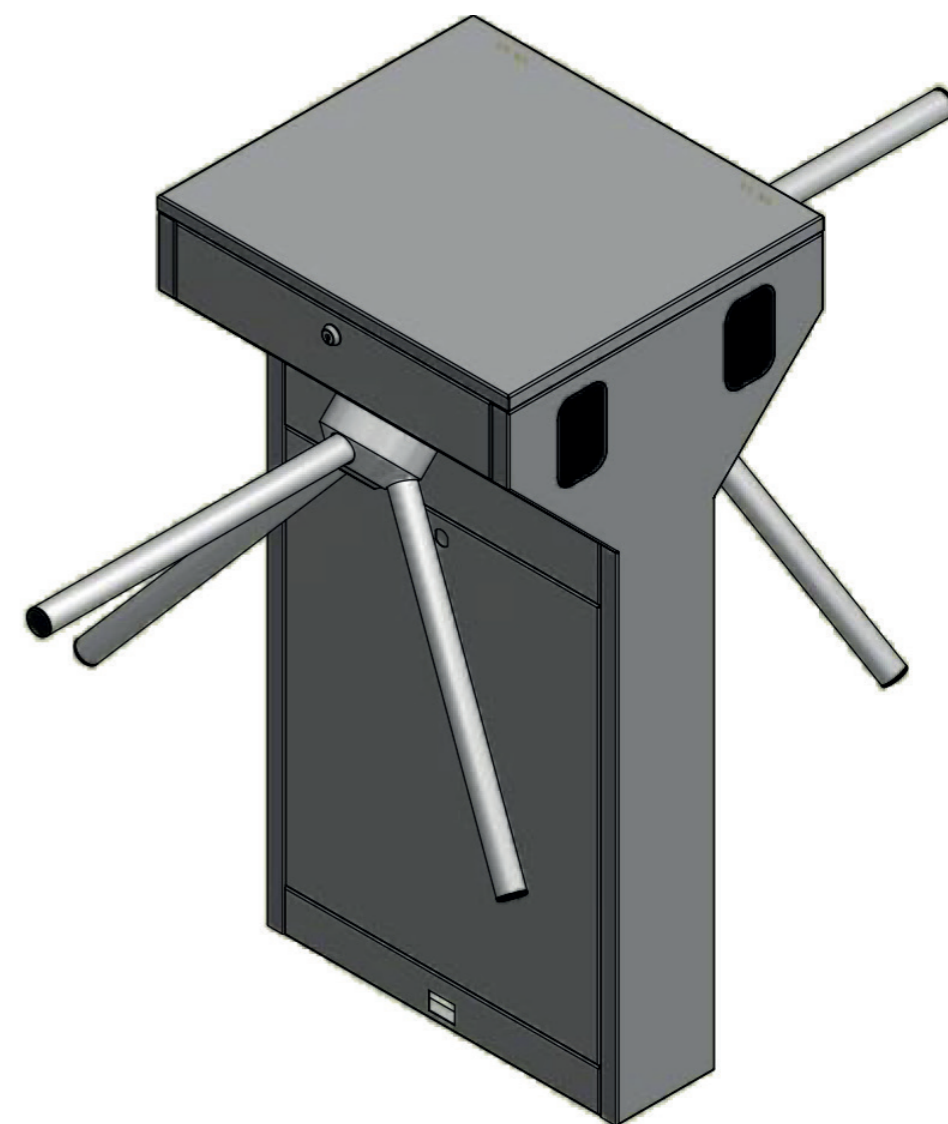

Conessioni elettriche e di segnale.

- A - Utilizzare un tubo in PVC 40 mm MAX.
- B - Cavo di alimentazione rete (230VAC), 3x2.5mmq
- C - Cavo di comando remoto 8x0.25mmq.

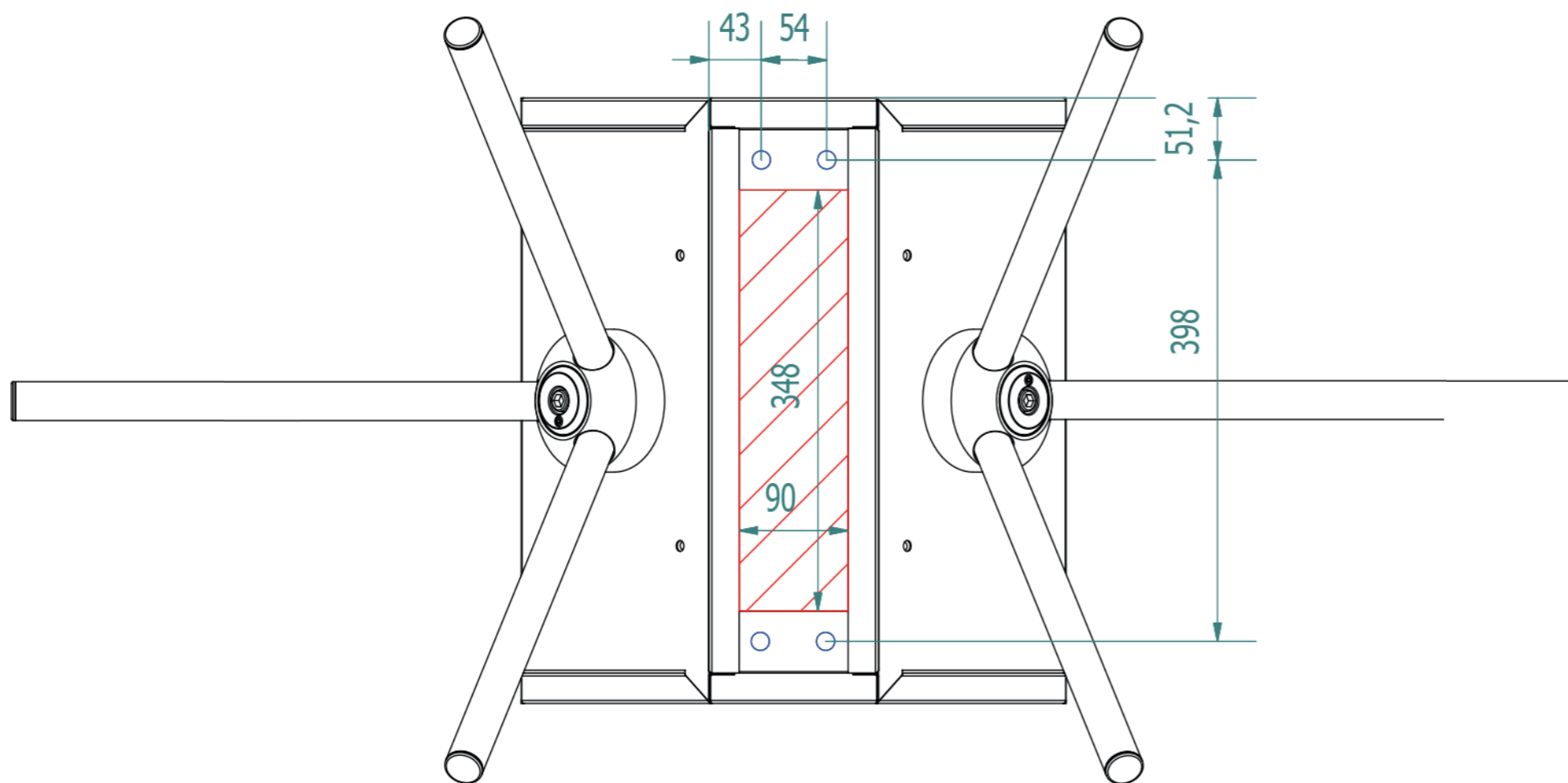

Punti di fissaggio a terra.

A - Praticare 14 mm e 100 mm di profondità per tasselli M8.

B - Utilizzare la sigillatura chimica.

